

THIS SHEET INCLUDES FITTING INSTRUCTIONS FOR THE FOLLOWING PARTS:

Secondary Alternator Cover Part No. EC-ZX6-2009-1-MSO / Secondary Clutch Cover Part No. EC-ZX6-2009-2-MSO

/ Secondary Pulse Cover Part No. EC-ZX6-2009-3-MSO /

Bullet Frame Race Slider Set RACE - Part No. FS-ZX6-2009-R

Bobbins Set Part No. BA12-10-MSO-SET / Lower Chain Guard Part No. CGA09-MSO



SECONDARY ALTERNATOR COVER
PART NO. EC-ZX6-2009-1-MSO

- 1 Remove lower fairing.
- 2 Remove 4 existing bolts from the stock Alternator cover, shown as position Bolt 1, 2, 3 & 4.
- 3 Place the Secondary Alternator Cover over the stock cover.
- 4 Assemble 4 replacement bolts loosely in the correct position as shown.
- 5 Tighten bolts to a Torque of 11Nm as per manufacturers recommendations. **DO NOT OVERTIGHTEN.**
- 6 Re-Fit lower Fairing.

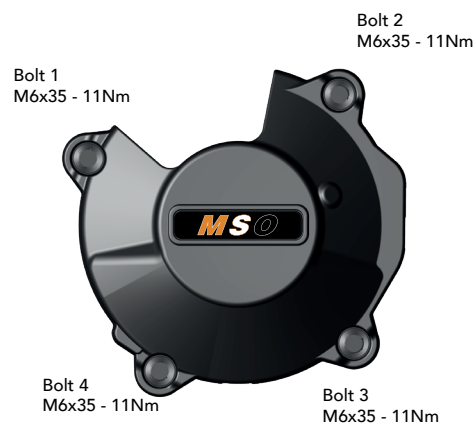
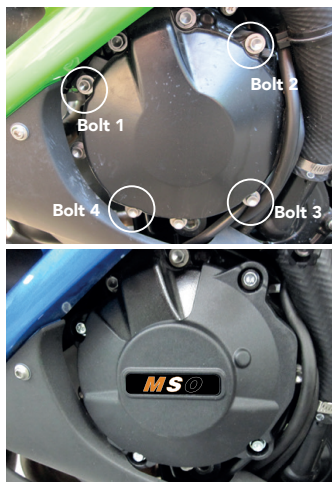

SECONDARY CLUTCH COVER
PART NO. EC-ZX6-2009-2-MSO

- 1 Remove lower fairing.
- 2 Remove 4 existing bolts from the stock clutch cover, shown as position Bolt 1, 2, 3 & 4.
- 3 Place the Secondary Clutch Cover over the stock cover.
- 4 Assemble 4 replacement M6x30 bolts, loosely in the correct position as shown.
- 5 Tighten bolts to a Torque of 11Nm as per manufacturers recommendations. **DO NOT OVERTIGHTEN.**

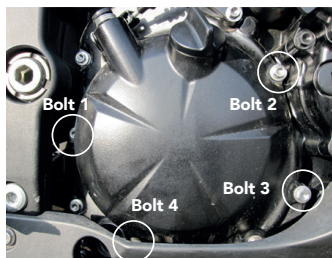

SECONDARY PULSE COVER
PART NO. EC-ZX6-2009-3-MSO

- 1 Remove the Upper and Lower Fairings. 2 Remove 4 existing bolts from the stock pulse cover, shown as position Bolt 1, 2, 3 & 4.
- 3 Place the Secondary Pulse Cover over the stock cover.
- 4 Assemble 2 replacement M6x35, 1 replacement M6x25 & 1 replacement M6x45 bolts, loosely in the correct position as shown.
- 5 Tighten bolts to a Torque of 11Nm as per manufacturers recommendations. **DO NOT OVERTIGHTEN.**
- 6 Re-Fit the Fairings.

